



# PROSIMED

Soluciones integrales del agua

## PROYECTOS Y SISTEMAS MEDIOAMBIENTALES S.L.

E-mail: [comercial@prosimed.com](mailto:comercial@prosimed.com)

Website: [www.prosimed.com](http://www.prosimed.com)

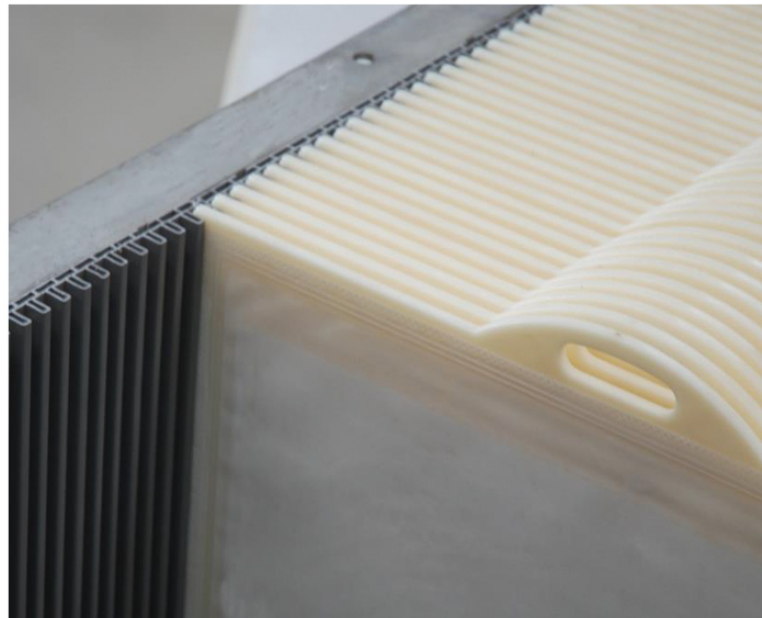

# FLAT PLATE ULTRAFILTRATION MEMBRANE FOR MBR

# PR 150-80-25-10

## Membrane characteristics

### PROSIMED MEMBRANE ELEMENTS

MEMBRANE TYPE	PR150	PR80	PR25	PR10
Effective area (m <sup>2</sup> )	1,50	0,80	0,25	0,10
Dimensions; Width/Length/Height (mm)	490×1750×7	490×1000×7	340×470×7	220×320×6
Weight (kg)	5,5	3,2	0,8	0,4
Pore size (µm)	≤0,10			
Membrane material	Polyvinylidene Fluoride (PVDF)			
Flux* [Litre/(Pc*Day)]	600 ~ 800	320 ~ 480	100 ~ 150	40 ~ 60
Aeration requirement [L/(Pc*Min.)]	≥10	≥10	≥8	≥6
pH	3 ~ 12			
Effluent turbidity [NTU]	<8			
Effluent [TSS] (mg/L)	≤10			

\* The flux may vary depending on the type of water to be treated. Performing a permeability test is recommended. The parameters in the table are based on tests applied to municipal water on a plate at a temperature of 25°C and a pressure of -10 kPa.

\*pc = per cartridge

### “IN SITU” CHEMICAL

Longer interval between cleaning cycles  
Over **3** months

Possibility of cleaning the membranes in situ, with sodium hypochlorite for organic fouling or with oxalic acid for inorganic fouling.

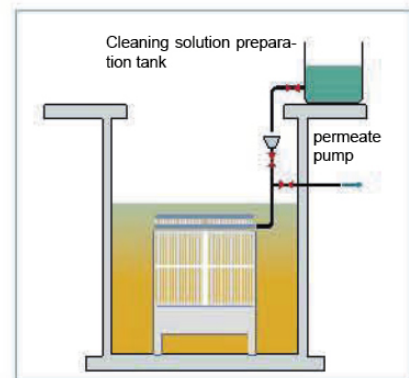

### EASY COMPONENT INSPECTION AND REPLACEMENT

Easy replacement  
In **15** minutes

The membrane elements can be replaced easily. This simplifies maintenance and reduces operating costs.

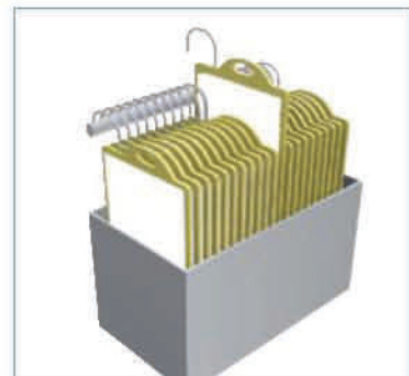

# Innovation and advanced technologies in MBR systems

## Outstanding features

- High working flux
- Long service life
- Excellent resistance to fouling

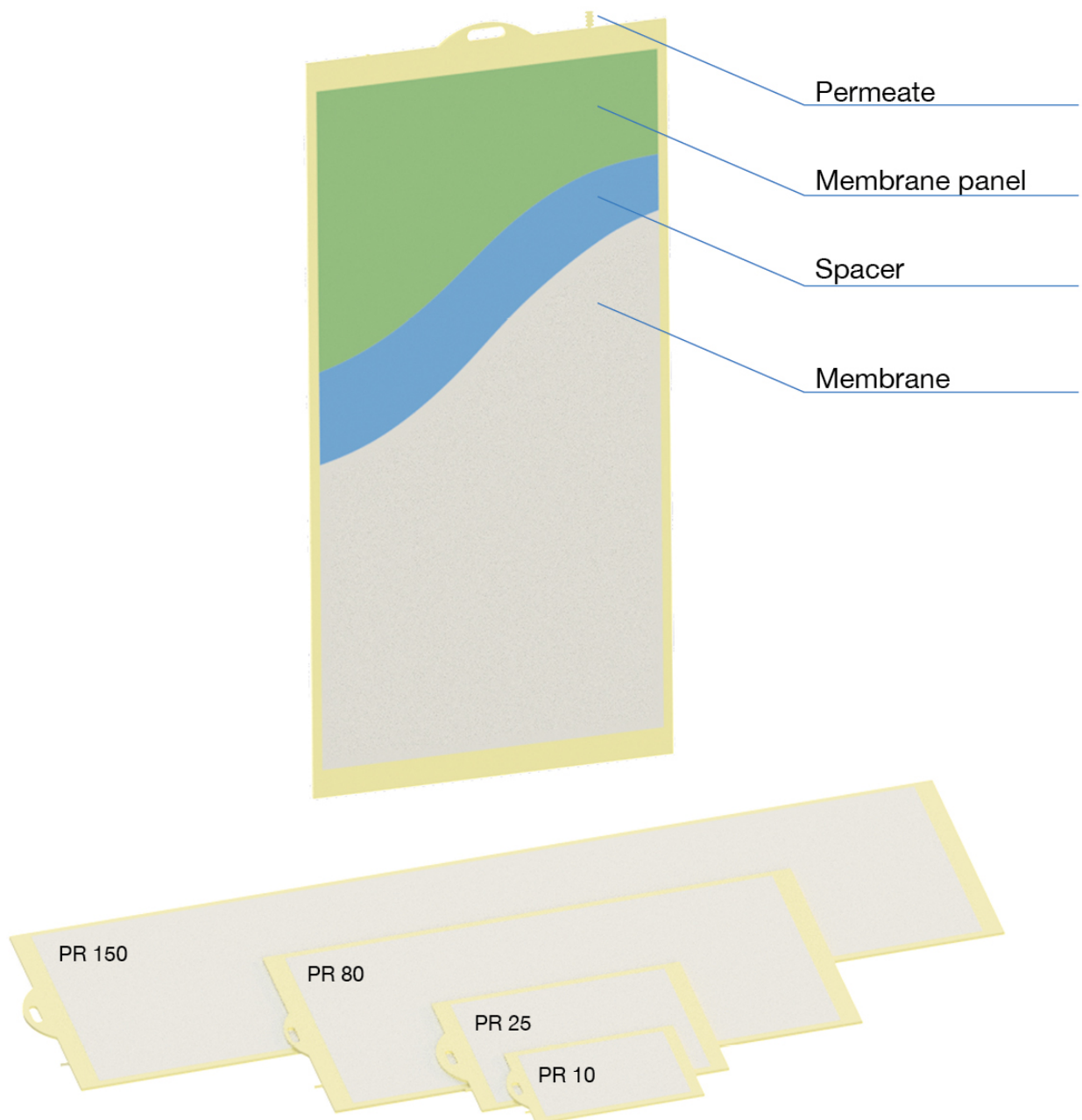

## Membrane models

## Features

### EXCELLENT CHEMICAL STABILITY

PROSIMED's flat plate membrane uses PVDF as a material, which provides good chemical stability and resistance to fouling.

This material is the most widely used in the water treatment membrane manufacturing sector.

### EXCELLENT FLUX AND PERMEATE QUALITY

The pore size of the PROSIMED's membranes is below 0.1  $\mu\text{m}$  (ultrafiltration). The membrane design increases their effective area per  $\text{m}^2$ , contributing to increased flux and high permeate quality.

MEMBRANE	Material	Pore size $\mu\text{m}$	PWP, L/ (h·bar·m <sup>2</sup> )	WCA, °	$\zeta$ , mV
Well-known brand	Chlorinated PE	0,4	336	78,4 ± 4,4	- 13,6
PROSIMED	PVDF	0,1	515	74,1 ± 1,2	- 4,0

### EXCELLENT RESISTANCE TO FOULING

PROSIMED's membrane offers ultrafiltration with an asymmetrical structure. This structure has a series of advantages, such as low flow resistance and excellent resistance to fouling phenomena. The air stream prevents larger particles from getting stuck on the outer face of the membrane, while smaller particles are expelled through the wide area of the pore, preventing their fouling.

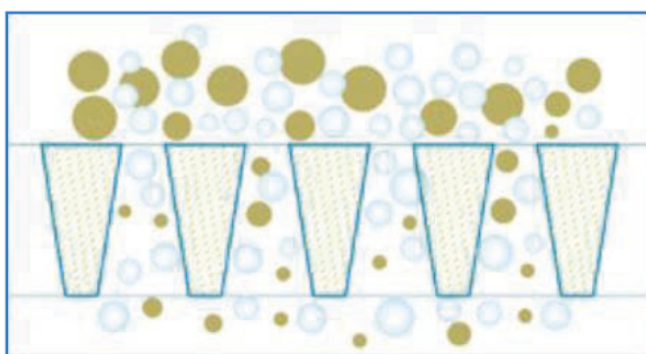
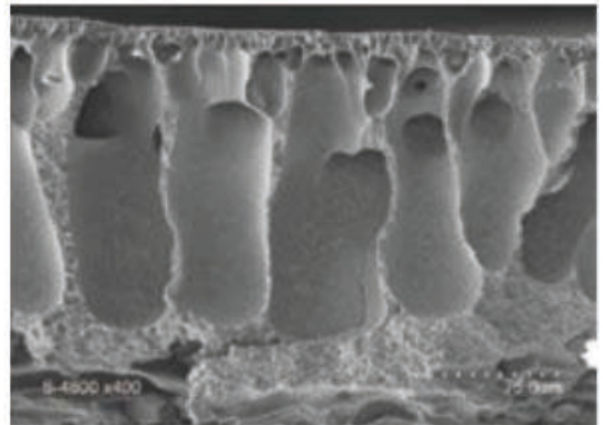

Asymmetrical structure of PROSIMED's membrane

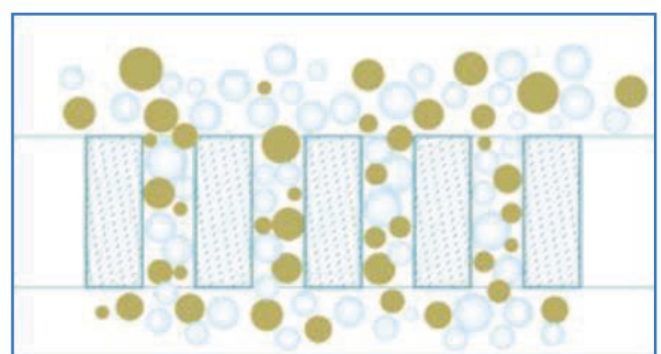

Symmetrical structure (other membranes)

## EXAMPLE OF REDUCTION IN PERMEABILITY WITH PURE WATER AND CONTACT ANGLES BEFORE AND AFTER AN ADSORPTION TEST

MEMBRANE	PWP Reduction, %	WCA Before, °	WCA After, °
Well-known brand	67,4	78,4 ± 4,4	86,8 ± 1,6
PROSIMED	28,5	74,1 ± 1,2	78,3 ± 2,4

### EXCELLENT CHEMICAL STABILITY

This enables operation with a higher concentration of activated sludge in the reactor (MLSS in the 8,000-15,000 mg/L range).

It prevents clogging phenomena, which can reduce the effective membrane area.

Application of air through the plates allows for easy, effective removal of adhered solids.



Hollow fibre

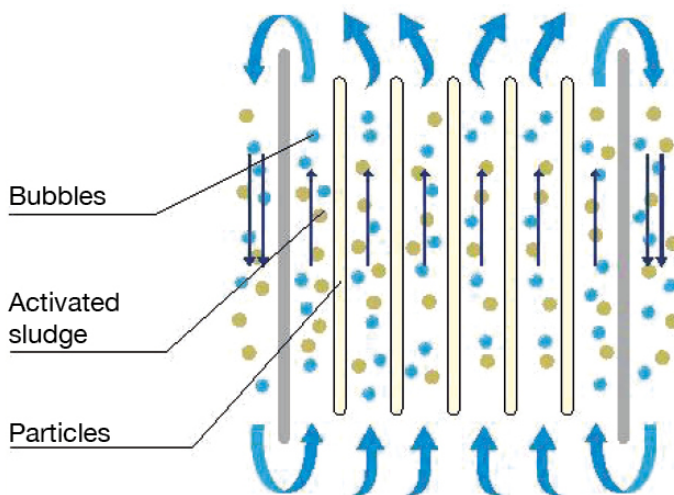

Flat plate membrane



Flat plate

The membrane is fixed to the frame by means of a double weld made using ultrasound, resulting in a very robust system. Hollow fibre is very susceptible to filament breakages, which makes it difficult to detect broken membranes and makes the quality of the permeate highly unstable.



Hollow fibre

## Prosimed membrane module

### Tubing

Connecting the membrane with the permeate

### Gasket and stops

Securing the membrane and preventing vibrations.

### Manifold

Collecting the permeate from all the module's plates.

### Cartridge (membrane)

Each membrane is engraved with a code to ensure individual traceability of each element.

### Guides

Fixing the membrane elements at uniform distances.

### Diffuser housing

Zone allowing for homogeneous mixing of air and mixed liquor.

### Diffuser

Supplying oxygen for biochemical reactions and preventing membrane fouling.



MEMBRANE	Plate Model	N° of plates	Area (m²)	Capacity (m³/día)	Máx. Capacity (m³/day)	Weight (Kg)	Air (L/min)
PR 80-50	80	50	40	20	40	340	500
PR 80-60		60	48	24	48	380	600
PR 80-80		80	64	32	64	470	800
PR 80-100		100	80	40	80	560	1000
PR 80-120		120	96	48	96	660	1200
PR 80-140		140	112	56	112	770	1400
PR 80-150		150	120	60	120	830	1500
PR 80-160		160	128	64	128	900	1600
PR 80-180		180	144	72	144	1000	1800
PR 80-200		200	160	80	160	1140	2000
PR 150-50		150	50	75	37,5	75	420
PR 150-60	60		90	45	90	510	600
PR 150-80	80		120	60	120	670	800
PR 150-100	100		150	75	150	730	1000
PR 150-120	120		180	90	180	890	1200
PR 150-140	140		210	105	210	1050	1400
PR 150-150	150		225	112,5	225	1140	1500
PR 150-160	160		240	120	240	1230	1600
PR 150-180	180		270	135	270	1400	1800
PR 150-200	200		300	150	300	1550	2000

## Membrane module specifications

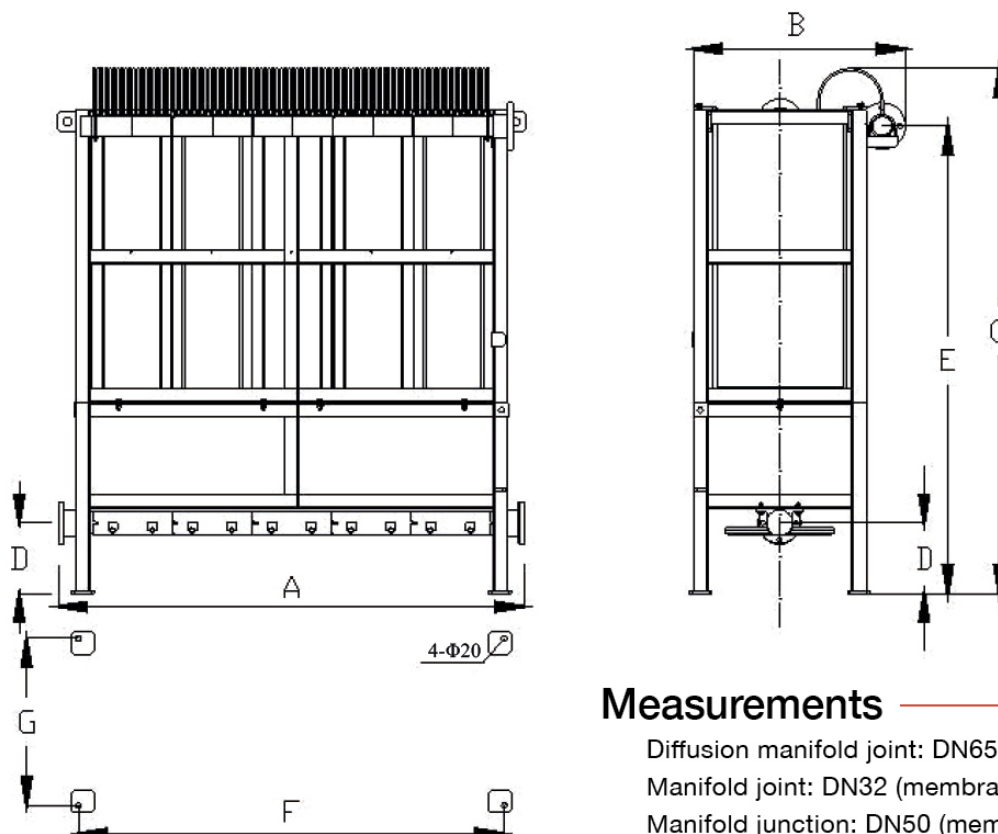

### Measurements

Diffusion manifold joint: DN65

Manifold joint: DN32 (membrane area ≤ 90 m<sup>2</sup>)

Manifold junction: DN50 (membrane area > 90 m<sup>2</sup>)

MODULE	Area (m <sup>2</sup> )	F low rate (m <sup>3</sup> /day)	A (mm)	B (mm)	C (mm)	D (mm)	E (mm)	F (mm)	G (mm)
PR 80-50	40	16-24	965	720	1860	240	1633	794	588
PR 80-60	48	19-28	1090					930	
PR 80-80	64	25-38	1385					1212	
PR 80-100	80	32-48	1670	1494					
PR 80-120	96	38-57	1950	1776					
PR 80-140	112	44-67	2230	2058					
PR 80-150	120	48-72	2375	2204					
PR 80-160	128	51-76	2530	2374					
PR 80-180	144	58-86	2838	2674					
PR 80-200	160	64-96	3100	2938					
PR 150-50	75	30-45	958	720	2560	240	2383	794	588
PR 150-60	90	36-54	1094				930		
PR 150-80	120	48-72	1376				1212		
PR 150-100	150	60-90	1658	1494					
PR 150-120	180	72-108	1940	1776					
PR 150-140	210	84-126	2222	2058					
PR 150-150	225	90-135	2368	2204					
PR 150-160	240	96-144	2538	2374					
PR 150-180	270	108-162	2838	2674					
PR 150-200	300	120-180	3102	2938					

The standard aeration compartment height is 700 mm. This can be adjusted as required. The size in the table is for reference.

## Specification: "Two-storey module"

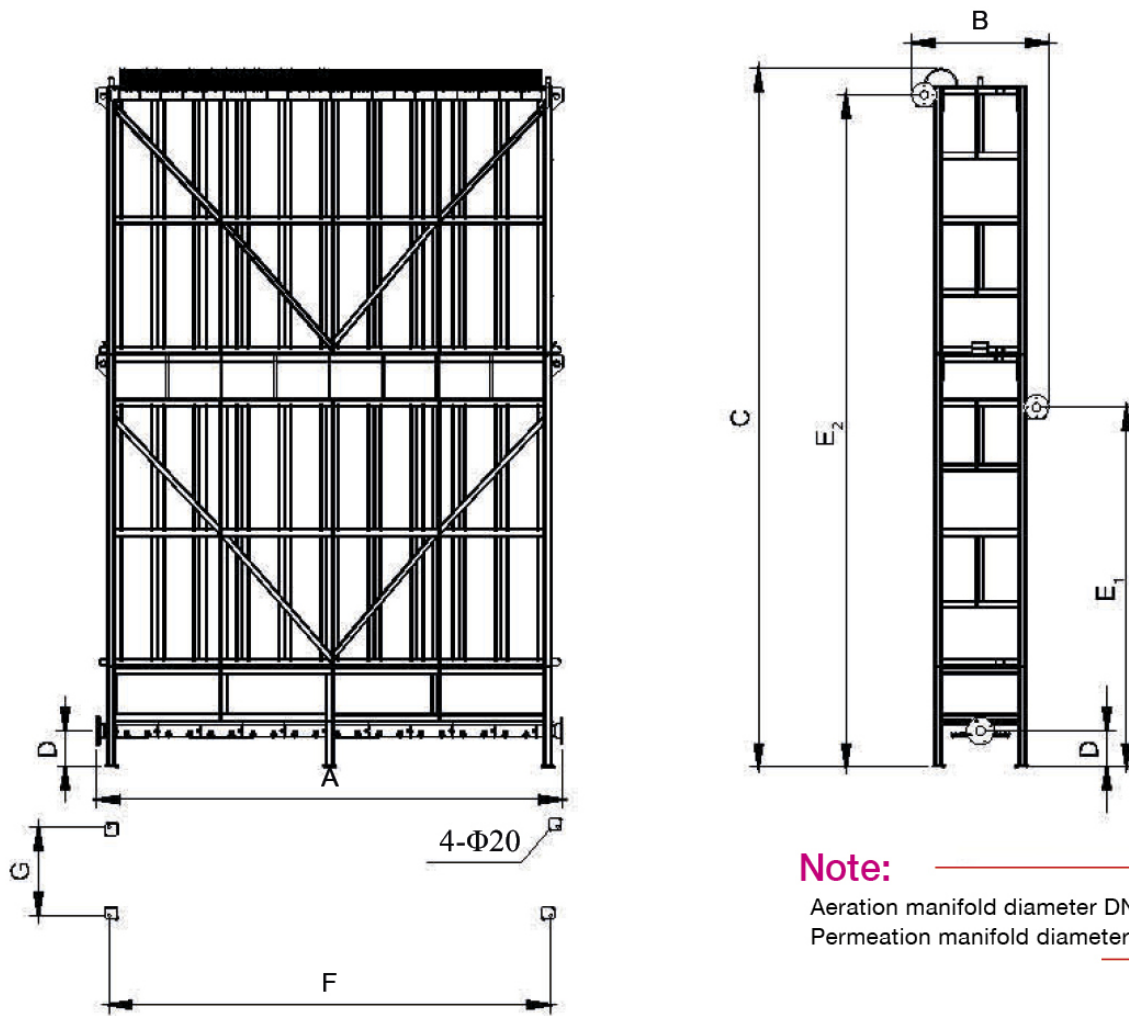

### Note:

Aeration manifold diameter DN65  
Permeation manifold diameter DN50

MODULE	Membrane Area (m <sup>2</sup> )	Capacity (m <sup>3</sup> /day)	A (mm)	B (mm)	C (mm)	D (mm)	E <sub>1</sub> /E <sub>2</sub> (mm)	F (mm)	G (mm)	Weight Kg	Air (L/min)
PR 80-100D	160	64-96	1658	760	3215	240	1615/2915	1494	588	1070	1600
PR 80-150D	240	96-144	2368					2204		1620	2400
PR 80-200D	320	128-192	3102					2938		2200	3200
PR 150-100D	300	120-180	1658		4775		2395/4475	1494		1420	1600
PR 150-150D	450	180-270	2368					2204		2200	2400
PR 150-200D	600	240-360	3102					2938		3030	3200

Approximate measurements, estimated loss for aeration.

## Advantages of MBR application

The combination of conventional activated sludge systems and membrane systems (MBR) enables efficient, innovative water treatment technology. Replacement of secondary sedimentation systems with MBR membrane modules enables water-solid separation to obtain ultrafiltered water quality. This allows reactor volumes to be reduced by up to 2.5 times compared to a conventional process.

This type of technology allows for removal of suspended solids. It also eliminates substances that are difficult to biodegrade, thanks to a longer SRT (sludge age), so improving reduction of nutrients (nitrogen and phosphorus), giving water that can be reused, when complemented with disinfection.

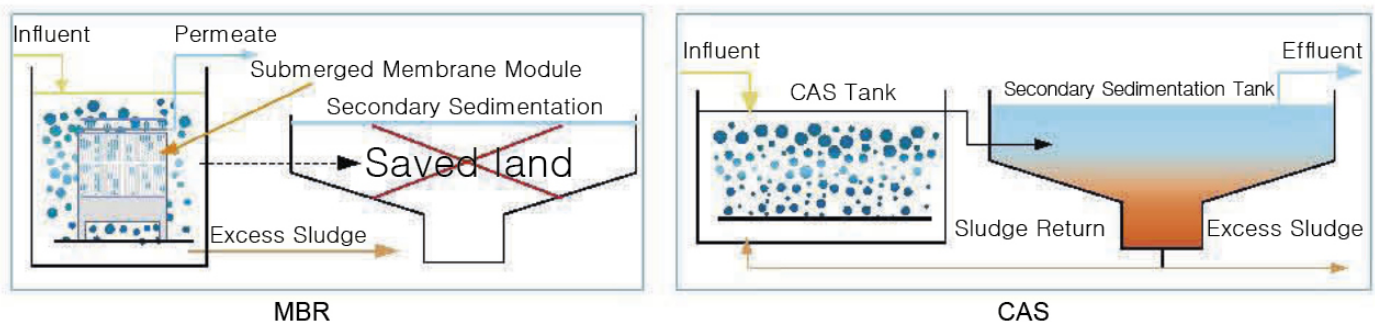

### Project: Cheese factory (Physico-chemical treatment+flotation+MBR)

WATER QUALITY	DQ0 (mg/L)	DBO (mg/L)	SS (mg/L)	NH3-N (mg/L)	TN (mg/L)	TP (mg/L)	Turbidity (mg/L)	pH
Influent	≤12500	≤7500	≤800	≤250	ND	ND	ND	5-10
Effluent	<50	<15	<10	<10	<10	<0,5	<1	6~9



### Project: Egg product company (Physico-chemical treatment+flotation+MBR)

WATER QUALITY	DQ0 (mg/L)	DBO (mg/L)	SS (mg/L)	NH3-N (mg/L)	TN (mg/L)	TP (mg/L)	Turbidity (mg/L)	pH
Influent	≤12000	≤8500	≤920	≤340	ND	ND	ND	9-10
Effluent	<50	<20	<10	<10	<7	<1	<1	6~9



This certificate is issued to:

## Proyectos y Sistemas Medioambientales, S.L. (PROSIMED)

Lloyd's Register España, S.A. carried out the inspection during the fabrication, installation and operating testing of the

**FLAT ULTRAFILTRATION MEMBRANES PR 150-80-25-10 + FRAME serial number: 2020.03**

The above-mentioned equipment was inspected based on the following documents:

- PROSIMED product specification PR membrane technical data sheet

PR membrane technical data sheet

Modelo Membrana		PR 150	PR 80	PR 25	PR 10
<b>Propiedades</b>					
Área efectiva	[m <sup>2</sup> ]	1,50	0,80	0,25	0,10
Longitud	[mm]	1750	1000	470	320
Anchura	[mm]	490		340	220
Profundidad	[mm]	7			6
Peso en seco	[kg]	5,5	3,2	0,8	0,4
Tamaño poro	[µm]	≤0,1009			
Material marco	-	ABS			
Material membrana	-	PVDF			
<b>Condiciones trabajo</b>					
Airación	[l/p min]	≥ 10	≥ 10	≥ 8	≥ 6
Presión transmembránica (TMP)	[mbar]	≤ 250			
Presión limpieza	[mbar]	≤ 100			
pH	-	3~12			
Temperatura	[°C]	5~40			
Concentración licor mixto	[mg/l]	8.000~12.000			
<b>Rendimiento</b>					
<sup>(1)</sup> Flux	[l/p/día]	600~800	320~480	100~150	40~60
Turbidez efluente	[NTU]	≤ 2			
SS efluente	[mg/l]	≤ 10			

\* El flux puede variar en función de las condiciones de trabajo. Se recomienda realizar pruebas de permeabilidad para cada caso. Los parámetros de trabajo y de instalación son los aplicados para aguas urbanas sobre membranas, a una temperatura de 25°C y una presión de 0,10 MPa.

The flux may vary depending on the type of water the line treated. permeability test is recommended. The working and installation parameters are those that are applicable to municipal wastewater at a temperature of 25°C and a pressure of 0.10 MPa.

- “Flat membrane system” installation, maintenance and operating manual 06/05/2021
- Legislation applicable to water quality: Spanish Royal Decree 1620/2007 of 7 December

Test Sheets attached  Yes  No

Lloyd's Register Group Limited, its affiliates and subsidiaries and their respective officers, employees or agents, individually and jointly, are referred to in this clause as “Lloyd's Register”. Lloyd's Register accepts no responsibility and will not be liable to any person for any loss, damage or expense caused by reliance on the information or advice provided herein or in any other way, unless that person has entered into a contract with the relevant Lloyd's Register entity for the provision of this information or advice and, in that case, any liability will be exclusively in accordance with the terms and conditions set out in that contract.

- Values indicated by PROSIMED to be certified:

E-COLI(ufc/100 ml))	NEMATODES (ufc)	LEGIONELLA (ufc)	DQO (mg/l)	DBO5 (mg/l)	SST (mg/l)	Turbidity (NTU)
≤4 unidades	<1huevo/10 l	<100UFC/l	<65	<15	≤10	≤2

- ARALAB laboratory reports
- Flow check expressed in litres/m2h:

Minimum flow rate value: 15.29 litres/m2h

Maximum flow rate value: 21.48 litres/m2h

Average flow value from 05/02/2021 and 12/03/2021: 16.76 litres/m2h

The following documents should be consulted for further information on the carrying out and certification of membranes as a third party: Inspection reports Nos. 1 & 2, Inspection certificate No. PRJ16284.3, Certificate No. PRJ16284.4 & Certificate No. PRJ16284.5.

The result of the checks indicated in this certificate was satisfactory.



AITZIBER GORRIÑO-BEASKOA  
Surveyor de Lloyd's Register España S.A.  
Member of the Lloyd's Register group

Installation, operation and maintenance manual

## **FLAT MEMBRANE SYSTEM**



**CE Marking**



## 2. OVERVIEW

### 2.1. EQUIPMENT NAMEPLATE

The equipment nameplate, which indicates the CE marking, is located on the side of the equipment and contains the following information:

- A. Manufacturer's name and address
- B. Type of equipment
- C. Equipment model
- D. Serial no.
- E. Year of manufacture

**A**

 <b>PROSIMED</b> <small>Soluciones Integrales del agua</small>	PROSIMED S.L. POL. IND. UTZUBAR NAVE 7 31893 - ARBIZU (NAVARRA) SPAIN TFNO (+34) 948 248143	
<p><b>B</b> -</p> <p><b>C</b> -</p> <p><b>D</b> -</p> <p><b>E</b> -</p>	<p>EQUIPO: _____</p> <p>MODELO: _____</p> <p>Nº SERIE: _____</p> <p>AÑO FABR: _____</p>	

This section illustrates all the information you need to identify your equipment.

For spare parts or technical assistance, please refer to the information shown on the equipment nameplate.

If the plate deteriorates over time, a replacement must be ordered. Please indicate the reference numbers contained on that plate.

A copy of the information contained on the plate is delivered along with the equipment documentation, as the nameplate is not accessible when the equipment is submerged.



#### **IMPORTANT**

*This nameplate is part of the equipment and must not be removed for any reason..*

Analyses

Full IWTP line

Proyectos y Sistemas Medioambientales

CHEESE FACTORY IWTP 2019: Analysis 7/03/2019 **RAW, UNTREATED**

DATOS IDENTIFICATIVOS DE LA MUESTRA

TIPO DE MUESTRA: Aguas residuales y lixiviados T.M.:  
 S/ REFERENCIA: 398-2019-00010852 LOCALIZACIÓN:  
 CÓDIGO MUESTRA: 27004884/2  
 FECHA/HORA LLEGADA: 07/03/2019 11:30 POL:

Análisis	Resultado	Unidades	Método de análisis/F
PH	5,7		Potenciometría/C51
MATERIAS EN SUSPENSIÓN	526	mg/l	Gravimetría/C51101
DQO	10363	mg O2/l	Titulación volumétr
DBO5	>4000	mg O2/l	Método manométr
NITROGENO KJELDAHL	257	mg/l	Titulación volumétr
NITRATOS	<1,00	mg/l	Cromatografía iónica
NITRÓGENO AMONICAL	112	mg/l	Titulación volumétr
NITRITOS	<1,00	mg/l	Espectrofotometría
NITROGENO TOTAL	257	mg/l	Cálculo/C5110271

Análisis	Resultado	Unidades
NITRATOS	0,56	mg/l
NITRITOS	<1,00	mg/l
DBO5	8000	mg O2/l

Proyectos y Sistemas Medioambientales

CHEESE FACTORY IWTP 2019: Analysis 7/03/2019 **DAF OUTLET WATER**

DATOS IDENTIFICATIVOS DE LA MUESTRA

TIPO DE MUESTRA: Aguas residuales y lixiviados T.M.:  
 S/ REFERENCIA: 398-2019-00010853 LOCALIZAC:  
 CÓDIGO MUESTRA: 27004885/2  
 FECHA/HORA LLEGADA: 07/03/2019 11:30 POL:  
 MENÚ/ANÁLISIS: PARCELA:  
 PORTADOR: Transportista CULTIVO:  
 VARIEDAD:

Las incertidumbres de las técnicas acreditadas por ENAC están calculadas y a disposición del cliente. Las interpretaciones no están amparadas por la acreditación de ENAC.

Análisis	Resultado	Unidades	Método de aná
PH	5,7		Potenciometri
MATERIAS EN SUSPENSIÓN	263	mg/l	Gravimetría/C/
DQO	2660	mg O2/l	Titulación volu
DBO5	2400	mg O2/l	Método menor
NITROGENO KJELDAHL	48,6	mg/l	Titulación volu
NITRATOS	70	mg/l	Cromatografía
NITRÓGENO AMONICAL	110,0	mg/l	Titulación volu
NITRITOS	61,8	mg/l	Espectrofoton

Proyectos y Sistemas Medioambientales

CHEESE FACTORY IWTP 2019: Analysis 7/03/2019 **MBR WATER-DISCHARGE TO RIVER**

DATOS IDENTIFICATIVOS DE LA MUESTRA

TIPO DE MUESTRA: Aguas residuales y lixiviados T.M.:  
 S/ REFERENCIA: 398-2019-00010854 LOCALIZACIÓN:  
 CÓDIGO MUESTRA: 27004886/2  
 FECHA/HORA LLEGADA: 07/03/2019 11:30 POL:  
 MENÚ/ANÁLISIS: PARCELA:  
 PORTADOR: Transportista CULTIVO:  
 VARIEDAD:

Las incertidumbres de las técnicas acreditadas por ENAC están calculadas y a disposición del cliente. Las interpretaciones no están amparadas por la acreditación de ENAC.

Análisis	Resultado	Unidades	Parámetros Directiva	Límite vertido a cauce 91/271/CEE
PH	7,8		pH	6-9
MATERIAS EN SUSPENSIÓN	<10,0	mg/l	SST	35 mg/l
DQO	<30	mg O2/l	DQO	125 mg/l
DBO5	<10	mg O2/l	DBO5	25 mg/l
NITROGENO KJELDAHL	<5,00	mg/l	N.Total	15 mg/l
NITRATOS	<1,00	mg/l	Fósforo tot	2 mg/l
NITRÓGENO AMONICAL	<10,0	mg/l		
NITRITOS	<1,00	mg/l		

## Water discharged to river

### Proyectos y Sistemas Medioambientales

CHEESE FACTORY IWTP 2019: PERMEATE WATER / DISCHARGE TO RIVER



## Fields of application





# PROSIMED

Soluciones integrales del agua

## PROYECTOS Y SISTEMAS MEDIOAMBIENTALES S.L.

E-mail: [comercial@prosimed.com](mailto:comercial@prosimed.com)

Website: [www.prosimed.com](http://www.prosimed.com)

### Production Workshop | Fábrica | Usine de Production

Pol. Industrial Utzubar, nave 7 | 31839 - ARBIZU (Navarra) Spain | Tel. +34 948 567 096



### Technical Office | Oficina Técnica | Bureau Technique

Avda. Juan Pablo II, 3 – local 5 | 31006 PAMPLONA (Navarra) Spain | Tel. +34 948 248 143

## COMPREHENSIVE WATER TREATMENT